

# QUALITY CONTROL IMAGING DEVICES

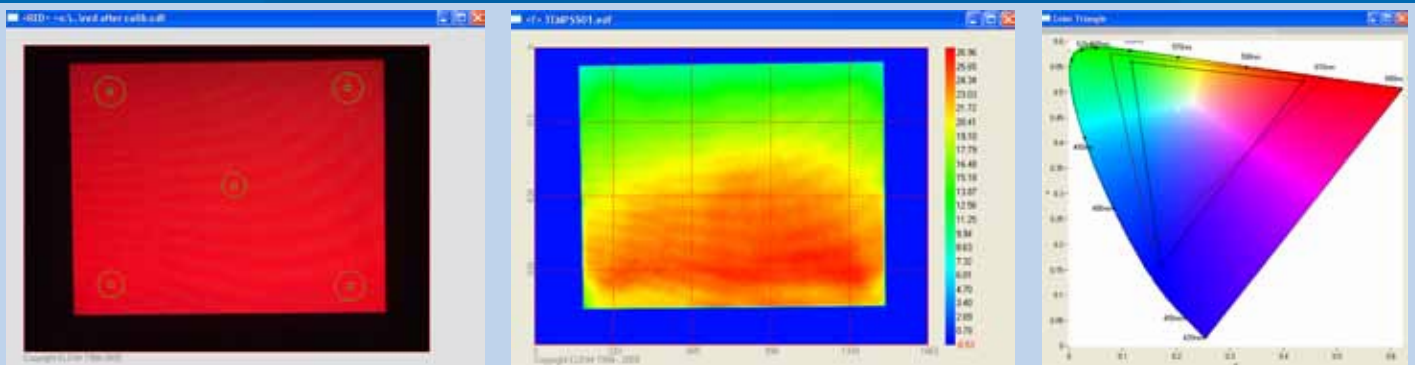

COST EFFECTIVE SOLUTION FOR HOMOGENEITY MEASUREMENT OF LUMINANCE & CHROMATICITY

iSENSE & iSENSE-Color



ADVANCED LIGHT ANALYSIS by ELDIM



CNC optical laboratory



Stitching Interferometer



Leybold A700QE in clean room environment



ELDIM clean room with alignment systems

## iSENSE description

**iSense** is a calibrated high resolution CCD camera with excellent signal over noise ratio coupled with a distortion free imaging optics. It is dedicated to photometry thank to its telecentric optical setup and a precise calibration of its spectral response.

### High Sensitivity

**iSense** is equipped with a Peltier cooled CCD sensor with true 16-bit analog digital converter. The very high spatial resolution of the CCD sensor (8.2M pixels) allows detection of very low light levels while maintaining a good resolution. Two versions with monochrome and color sensor are available.

### High Accuracy

**ELDIM** is manufacturing on its own all the key components of its systems. The quality of the optics is optimum thanks to advanced technologies, CNC polishing, magneto-rheological polishing or stitching interferometry. Antireflective coatings and optical alignments are performed in house to reduce straight light and parasitic polarization. **iSense** uses an imaging objective telecentric on the sensor side, that ensure that the light collection efficiency is stable for all the positions of the objects in front of the optics. In addition, the spectral response is measured precisely for each system and, even if specific calibration is needed for each type of source to measure color or luminance, the calibration procedure is simplified.

### High Dynamic

**iSense** can be used with different neutral densities to adjust the response of the system and optimize the signal over noise ratio of the measurements. Any density from ND 0.6 to 7 is available upon request for all kinds of applications.

### A range of imaging objectives

**iSense** is available with objectives of different aperture ( $8^\circ$  and  $16^\circ$ ). Additional optics for high magnifications are also available.



Photographs of iSense

## Luminance & Color calibration

Monochrome version of **Isense** is equipped with a photopack filter that, combined with the spectral response of the sensor, adjusts the spectral response of the system to the Y CIE curve. On the contrary, accurate color measurements using color CCD sensor cannot be achieved without a specific calibration for each type of source under investigation. Indeed, the spectral response of R, G and B pixels cannot be adjusted directly on the CIE curves. For **ISenseColor** it is precisely measured for each system and then used for the calibration.

### Standard sample

When measuring color displays, the most simple method is to measured intensities of the three types of pixels  $I_R, I_G, I_B$  obtained for the three primary colors r, g and b of a reference display where the X,Y,Z CIE values are already known. A set of 9 calibration parameters  $a_{ij}$  is calculated to retrieve the X,Y,Z values following:

$$\begin{pmatrix} I_R^r & I_G^r & I_B^r \\ I_R^g & I_G^g & I_B^g \\ I_R^b & I_G^b & I_B^b \end{pmatrix} \begin{pmatrix} a_{1,1} & b_{1,2} & c_{1,3} \\ a_{2,1} & b_{2,2} & c_{2,3} \\ a_{3,1} & b_{3,2} & c_{3,3} \end{pmatrix} = \begin{pmatrix} X^r & Y^r & Z^r \\ X^g & Y^g & Z^g \\ X^b & Y^b & Z^b \end{pmatrix}$$

Any linear combination of the three primary color as what is occurring for the display light emission, is then measured accurately after this calibration. This procedure is implemented inside the measurement software and can be performed easily by the user. After this procedure, the accuracy is excellent for the type of display used for calibration.

### Specified spectral emission

Another way is to provide a priori the spectral signature of the three primary colors of a type of display (such as CCFL or white LED for example). Knowing the calibrated spectral response of the system, a calibration set of 9 parameters is automatically calculated. The accuracy is slightly reduced compared to the real calibration measurements but can be used more easily without spectrophotometer.

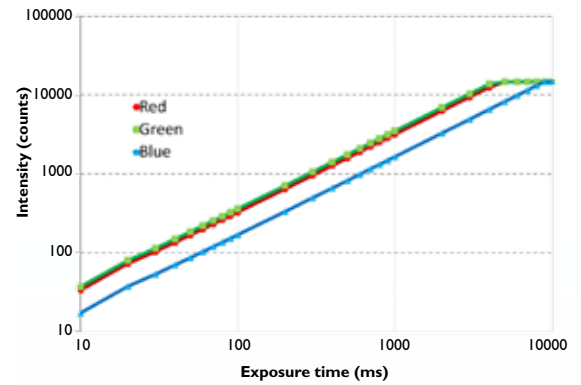

Linearity of the iSENSE-Color measured for the R, G and B pixels

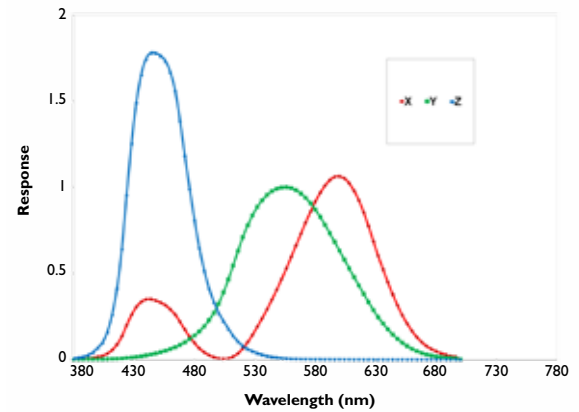

Definition of the CIE  $x(\lambda), y(\lambda)$  and  $z(\lambda)$  curves for color measurements

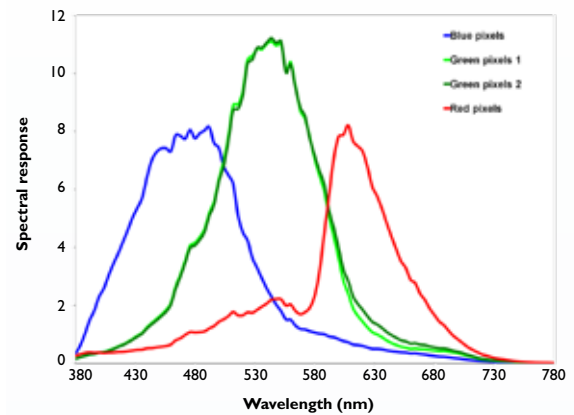

Measure spectral response of a iSenseColor

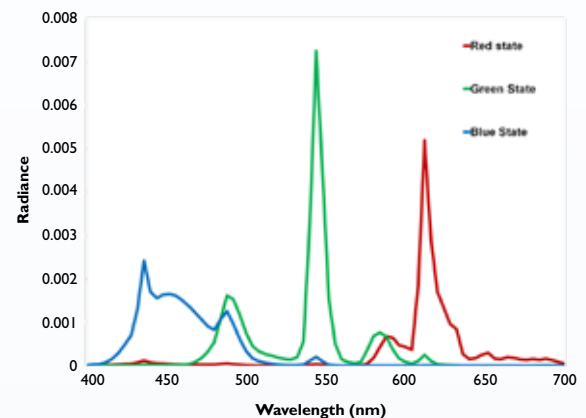

Primary spectral signatures for a CCFL LCD display

	IsenseColor			Spectrophotometer			Error		
	Y	x	y	Y	x	y	Y	x	y
Black	0.206	0.2467	0.2415	0.206	0.2476	0.2442	0.17%	0.0009	0.0027
Grey level 127	7.116	0.3331	0.3288	6.840	0.3335	0.3295	4.03%	0.0004	0.0007
Grey Level 159	19.560	0.3240	0.3229	19.354	0.3243	0.3235	1.06%	0.0002	0.0006
Grey Level 191	39.560	0.3199	0.3194	39.766	0.3198	0.3199	0.52%	0.0001	0.0005
Grey Level 223	65.150	0.3162	0.3188	65.936	0.3158	0.3188	1.19%	0.0003	0.0000
White	96.130	0.3179	0.3222	98.888	0.3172	0.3219	2.79%	0.0007	0.0003
Magenta	31.710	0.3434	0.1702	32.480	0.3432	0.1698	2.37%	0.0001	0.0004
Yellow	87.880	0.4225	0.4881	89.668	0.4228	0.4891	1.99%	0.0003	0.0010
Light Blue	68.510	0.2083	0.3151	69.666	0.2078	0.3149	1.66%	0.0006	0.0003
Red	23.910	0.6286	0.3270	24.748	0.6298	0.3263	3.39%	0.0012	0.0007
Green	61.660	0.2784	0.5978	62.922	0.2782	0.5993	2.01%	0.0002	0.0015
Blue	7.054	0.1460	0.0633	7.205	0.1458	0.0628	2.10%	0.0002	0.0005

Measured colors on a CCFL LCD after calibration and comparison to spectrophotometer

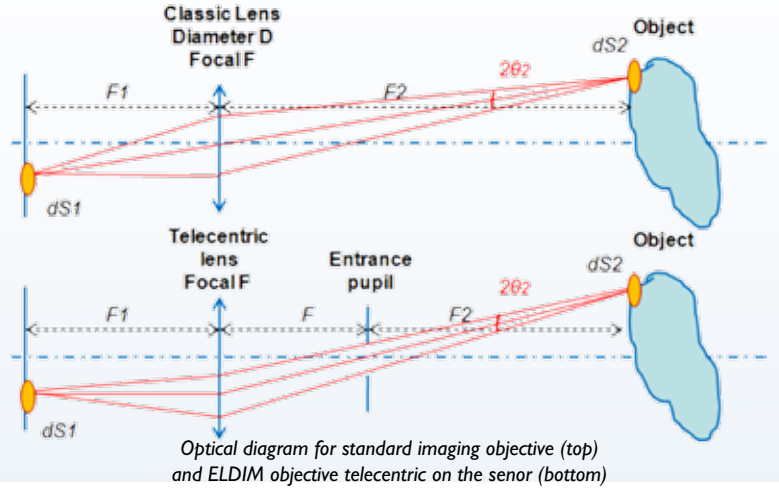
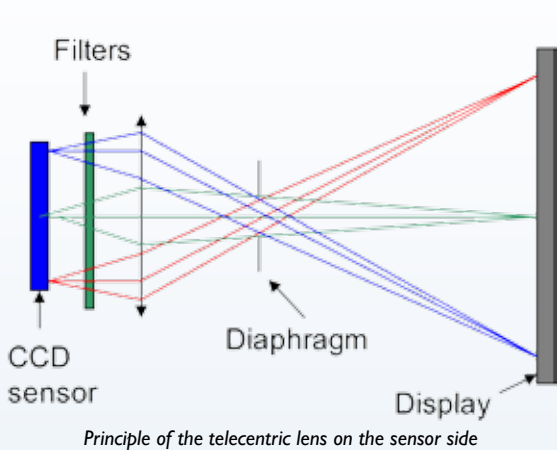

## The imaging optics

For accurate measurements the imaging optic plays a key role. Indeed, standard imaging optics suffer from a dependence of the flux with the distance to the object. One basic “solution” is to provide different sets of calibration for the system with all the possibilities of error that can occur. **ELDIM** uses a much better solution based on telecentric optic on the sensor side. A first obvious advantage is that all the light rays cross the filters with the same incidence what ensures the same spectral response everywhere on the image. Another key advantage is the independence of the flux with the object distance.

### Dependence of flux with distance for standard objectives

The flux emitted by an elemental surface  $dS_2$  of luminance  $L$  in the small angular cone  $2\theta_2$  is given by:

$$d\phi_2 = 2\pi L(1 - \cos \theta_2) dS_2 \approx \pi L \theta_2^2 dS_2$$

We want to calculate the flux collected by and elemental surface  $dS_1$  on the detector:

$$d\phi_1 = kd\phi_2 = k\pi L \theta_2^2 dS_2 = M_1 dS_1$$

The conservation of the geometric etendue gives the following relation between the surfaces:  $\frac{dS_1}{F_1^2} = \frac{dS_2}{F_2^2}$

Using the relation between  $F_1, F_2$  and the focal length  $F\#$  we finally obtain:

$$M_1 = \frac{k\pi LD^2}{4F\#^2} \left(1 - \frac{2F\#}{F_2}\right) = M_\infty \left(1 - \frac{2F\#}{F_2}\right)$$

The signal seen by the detector is then dependent on the distance of the object. At  $10F\#$  the reduction is about 20% as shown in the figure with a big impact on the accuracy.

### Flux stability for telecentric objectives

For a telecentric configuration  $dS_1/F_1^2 = dS_2/F_2^2$  and  $M_1$  is independent of the distance in first approximation. If we develop the cosines to the third term we can find:

$$M_1 = \frac{k\pi LD^2}{4F\#^2} \left(1 - \frac{3F\#^2}{16F_2^2}\right) = M_\infty \left(1 - \frac{3F\#^2}{16F_2^2}\right)$$

The figure shows a flux reduction lower than 1% for  $5F\#$  distance and lower than 0.1% for  $15F\#$ . A single calibration is then sufficient for all practical distances.

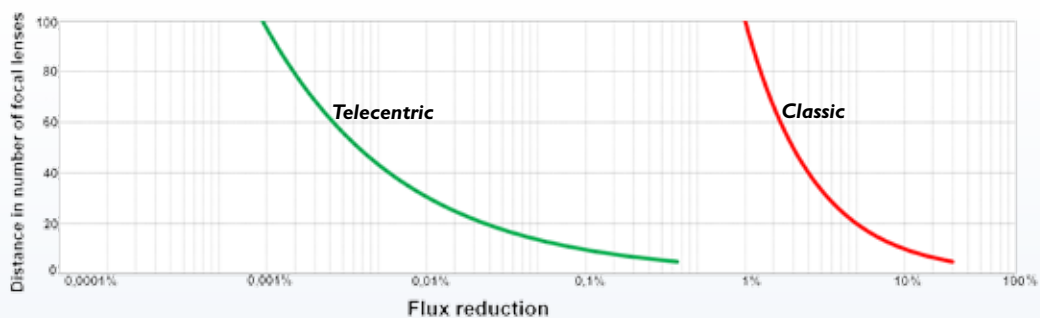

Theoretical dependence of the flux with the object distance (standard optics and telecentric optics)

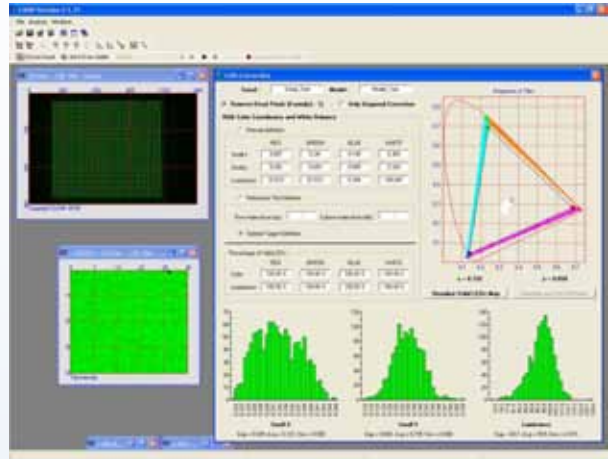
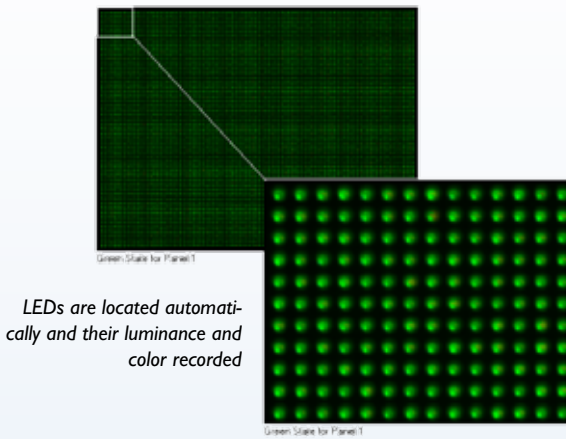

LWAP software interface for calibration coefficient computation

### Calibration of LED displays

LED displays always suffer from a lack of uniformity because of the dispersion of the LED characteristics. **ELDIM** provides a completely automated solution **LWAP** to calibrate LED display modules in an absolute way. Absolute color measurements are made for each type of LED separately. The software finds automatically all the LEDs on the panel and extracts their color and luminance. It is necessary to define the geometry of the pixel for the calculation of calibration coefficients. One red, one green and one blue LEDs are at least necessary but an additional white LED can be included.

The target color coordinates and luminance for each panel state is converted in tri-stimuli values X,Y and Z. For each pixel the correction matrix C is deduced in order to get:

$$\begin{bmatrix} X_{Red}^{Target} & X_{Green}^{Target} & X_{Blue}^{Target} \\ Y_{Red}^{Target} & Y_{Green}^{Target} & Y_{Blue}^{Target} \\ Z_{Red}^{Target} & Z_{Green}^{Target} & Z_{Blue}^{Target} \end{bmatrix} = \begin{bmatrix} X_{Red}^{Meas} & X_{Green}^{Meas} & X_{Blue}^{Meas} \\ Y_{Red}^{Meas} & Y_{Green}^{Meas} & Y_{Blue}^{Meas} \\ Z_{Red}^{Meas} & Z_{Green}^{Meas} & Z_{Blue}^{Meas} \end{bmatrix} \times \begin{bmatrix} C_1 & C_4 & C_7 \\ C_2 & C_5 & C_8 \\ C_3 & C_6 & C_9 \end{bmatrix}$$

**LWAP** computes automatically the different correction matrixes by solving each set of linear equations and stores them in different formats. Once all the correction coefficients have been written into the tiles, additional **iSENSE** measurements combined with color coordinates and luminance extractions can be realized in order to check the efficiency of the calibration method. After correction the panels show a much better homogeneity both in color and luminance.

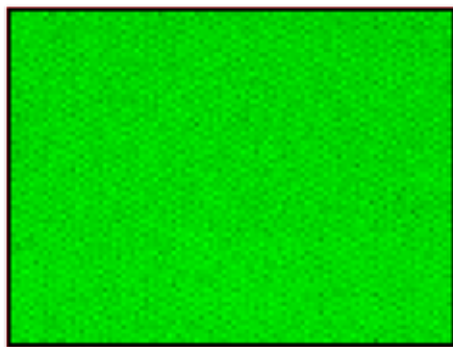

Panel 1 Correction 071

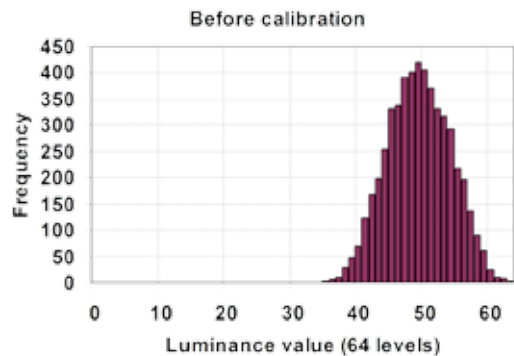

Green color & luminance dispersion before and after calibration.



Panel 1 Correction 071

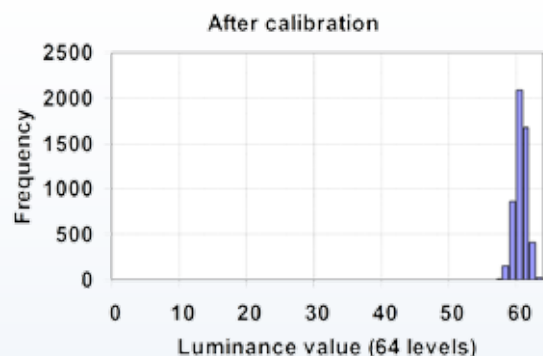

### MURA Defect detection

MURA defect detection requires a high quality sensor since it has to challenge the eyes sensibility which is in many aspects very high. In this respect, **iSENSE** is certainly the most sensitive solution of the market thanks to its cooled CCD sensor, high quality optics and high transmission filters. The other difficult task is to automatically analyze, quantify and classify the MURA defects. **ELDIM** provides in option a full automated solution **EZMURA** for this task. The software performs automatically the following operations:

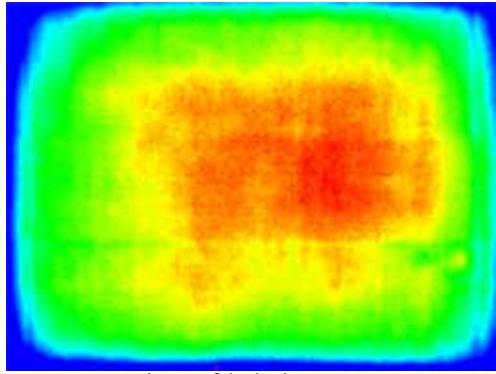
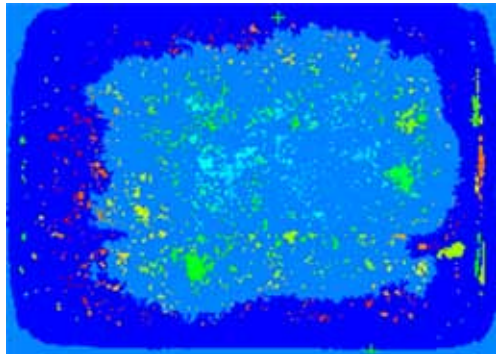
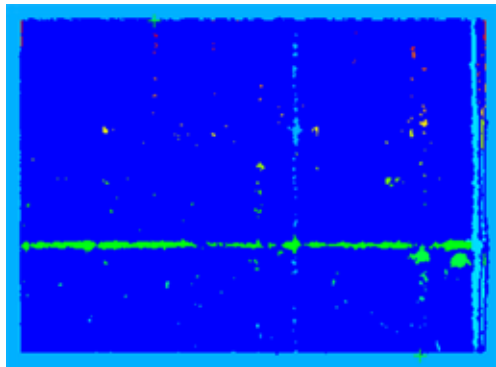

Image of display luminance



Iterative segmentation



Subtractive segmentation

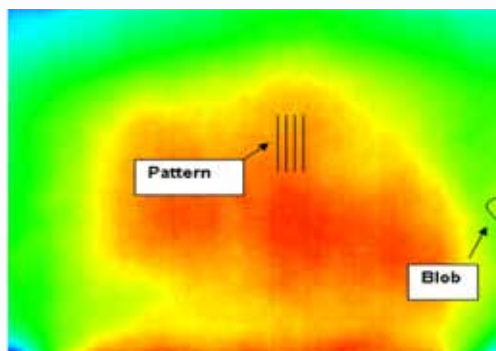
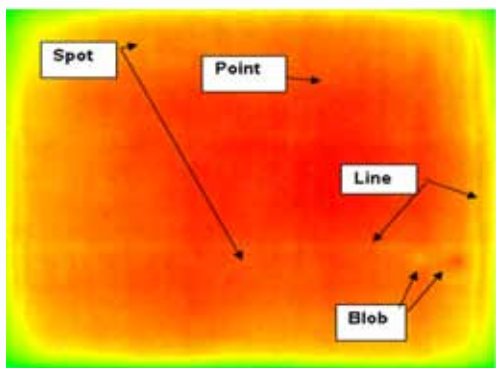

The different families of defect addressed by EZMURA

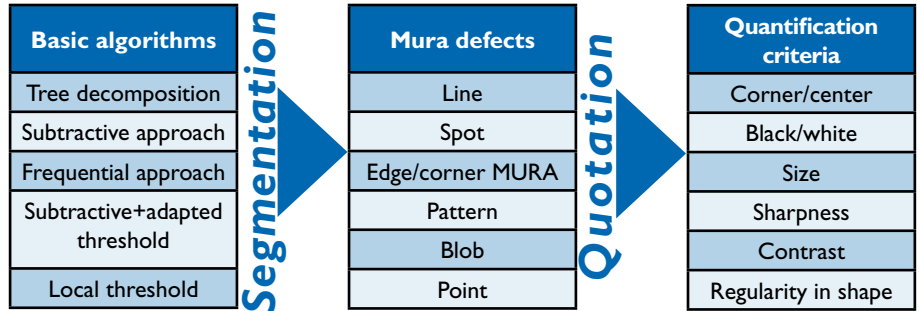

Segmentation allows finding defect entities in 2D luminance images from the display. A wide range of segmentation algorithms have been developed: local threshold, region growing, watershed, fuzzy clustering, edge detection, active contour (snakes), Markov random fields, neural networks... Because of MURA family complexity, it is impossible to find a single ideal algorithm able to detect simultaneously all kinds of MURA defects. Each segmentation approach has its own advantages and drawbacks and allows focusing only on a given kind of MURA defect. **EZMURA** software uses six different algorithms to detect different family of MURA defects.

Once a defect has been identified, it has to be quantify so as to decide whether its intensity is acceptable or not. **EZMURA** uses SEMI quantification or custom quantification so as to fit an existing quotation system (based on operator visuals). Critical values can be found (one for each sub classes of defect) and applied for final pass/fail assessment.

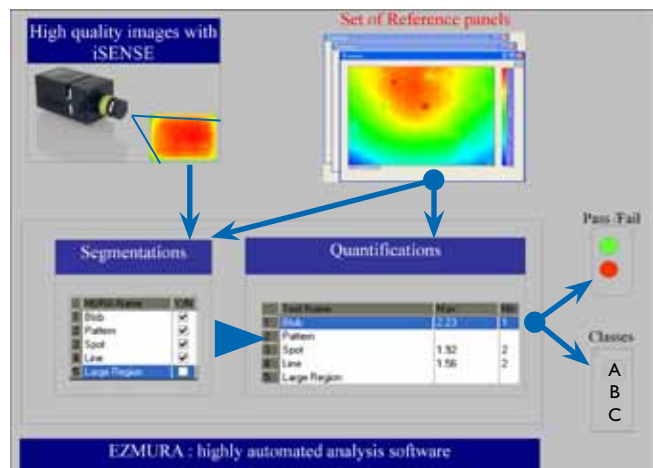

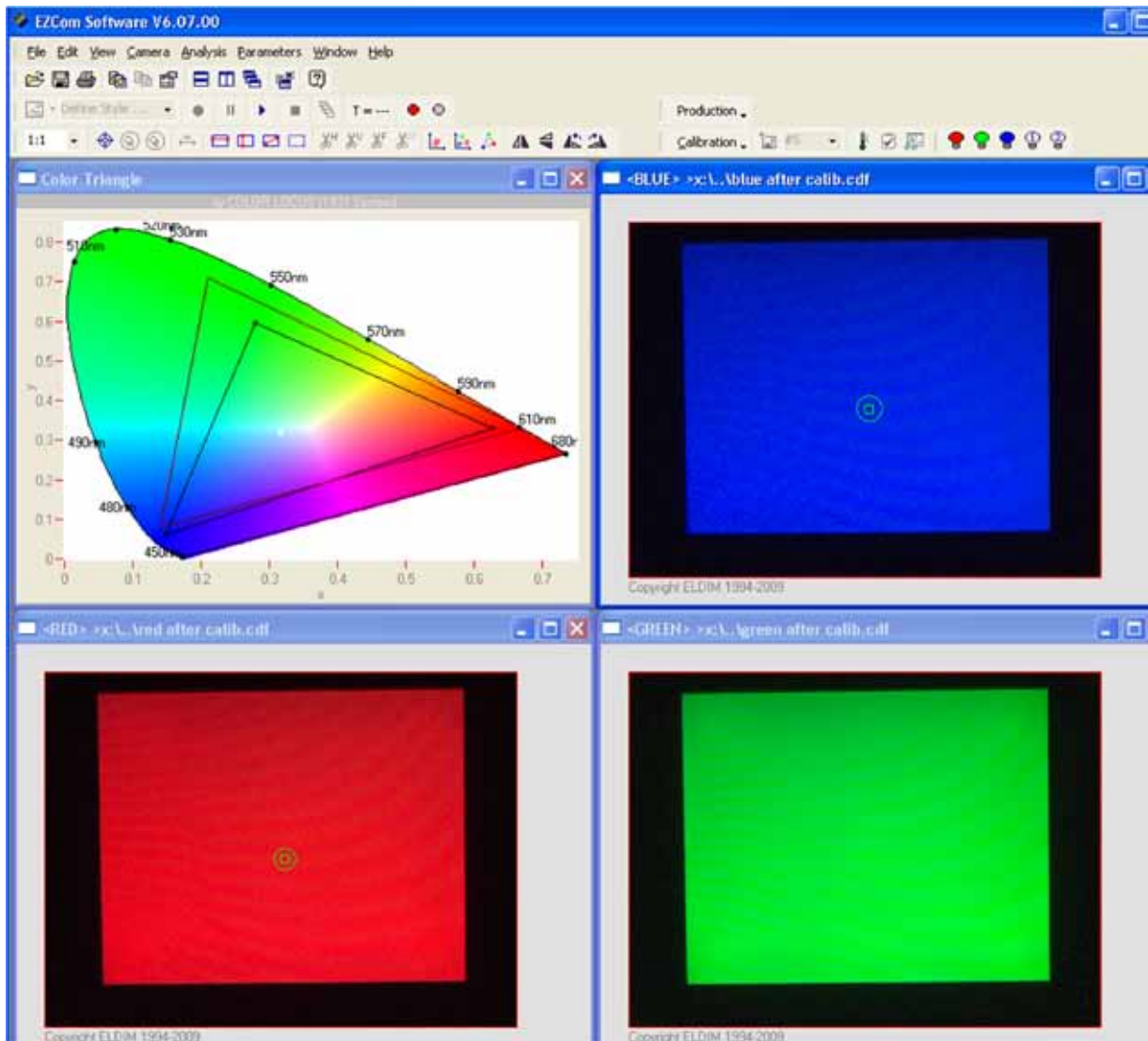

iSENSE comes with a complete software solution for measurement and data analysis.

### Some characteristics of the EZCom 6 software package for iSENSE

Features	Details	Version
<b>Measurement capacities</b>	Imaging Luminance	Standard
	Imaging Color	iSENSE-Color
<b>Data analysis</b>	Luminance contrast	Standard
	Cross section (Horizontal, Vertical and free), Isocurves, False Color representation, 3D representation	Standard
	Smoothing Filtering, Rotation, Clipping, R.O.I. extraction, Averaging, Contour extraction, Moiré removal	Standard
	Color unit: xy, u'v', Lu*v* or La*b*	iSENSE-Color
	Color intensity, Color Difference, Color Dispersion, Color Triangle, Color Temperature, Equivalent Wavelength	iSENSE-Color
<b>Data export</b>	Copy to clipboard	Standard
	Save in text and excel format	Standard
	Multi-spots statistics	Standard
<b>Programming capacities</b>	All features can be controlled by OCX interface	Standard
	Examples of automated measurements and analysis provided	Standard
<b>Additional softwares</b>	<b>EZMURA</b> for MURA defect detection and quantification	Option
	<b>LWAP</b> for LED wall calibration	Option

**Major specifications of iSENSE Series**

Common specifications		iSENSE	iSENSE-Color
Imaging lens	<i>Telecentric on sensor (option) Motorized focusing (option)</i>	Max 16° Max 8° Software adjustment	
Front entrance iris	<i>Diameter Other diameters (option)</i>	6mm From 2 to 10mm	
Additional optics	<i>For high spatial resolution (option) (option) (option)</i>	x1 x2 x4	
Density	<i>Manually adjusted in front of the imaging lens (option)</i>	From ND0.4 to ND7	
Sensor configuration	<i>Peltier cooled CCD grade I</i>	Monochrome 3300x2500 or 8.25M pixels	Color 3300x2500 or 8.25M pixels
Luminance range	<i>Without density With density (option)</i>	0.001 to 500Cd/m <sup>2</sup> up to 10M Cd/m <sup>2</sup> with ND filters	
Accuracy	<i>Luminance Chromaticity (x,y) RMS</i>	±3% after specific calibration (*1) ±6% with spectral input (*2) Not applicable	±3% after specific calibration (*1) ±6% with spectral input (*2) ±0.003 after specific calibration (*3) ±0.006 with spectral input (*4)
Repeatability	<i>Luminance Chromaticity</i>	±0.5% for full resolution (*5) Not applicable	±0.5% for full resolution (*5) 0.001 for full resolution
Measurement time	<i>Luminance Color</i>	<2s (*6) Not applicable	<2s (*6) <2s (*6)
Using condition	<i>Temperature range Humidity range</i>	0 to 30°C 0-85% non condensing	
Interface	<i>Compute controlled by OCX components</i>	USB 2.0	
Power	<i>Independent Power Supply</i>	AC adapter (100-240V 50/60Hz)	
Current consumption		90W	
Weight		4Kg	

(\*1) Specific calibration is required for each type of source. The accuracy is guaranteed only after this specific calibration for the type of source used for the calibration.

(\*2) Typical spectrum of the source under measurement must be input instead of making calibration.

(\*3) Specific calibration on the three primary colors of the display under investigation is needed. The accuracy is guaranteed only after this specific calibration for the type of source used for the calibration.

(\*4) Typical primary trichromatic spectra of the source under measurement must be input instead of making calibration.

(\*5) For a luminance higher than 100Cd/m<sup>2</sup>. This repeatability depends essentially on the signal over noise ratio and is given for full resolution in the table. When a binning level N is used it is divided by a factor of N. For a resolution of 330x250 the luminance repeatability is only ±0.03%

(\*6) Measurement times are highly dependent on the target and on the conditions. Given times are for a source with luminance level higher than 100Cd/m<sup>2</sup> and already determined exposure time.

**Outer dimension (unit mm)**

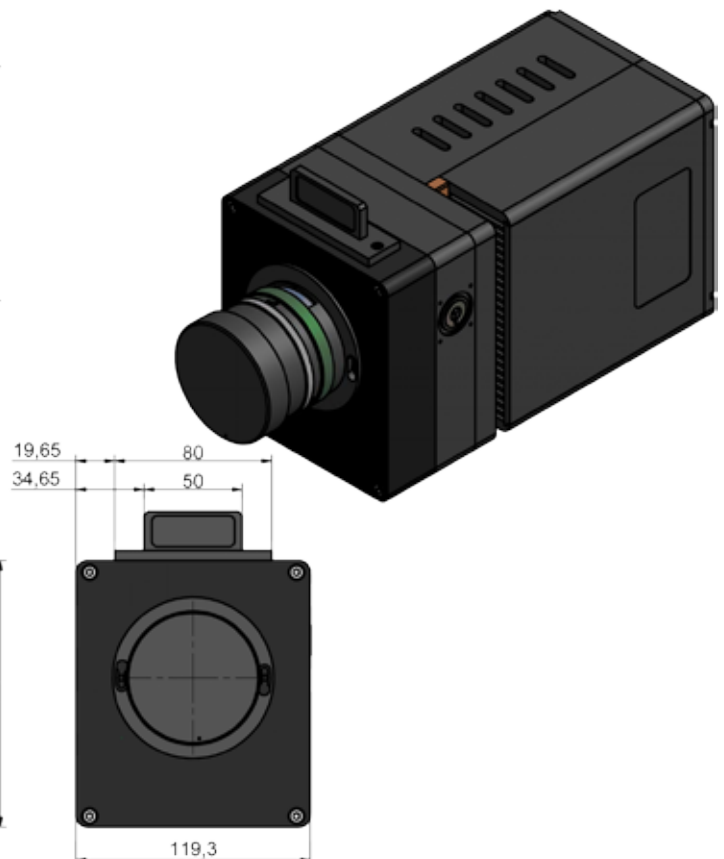
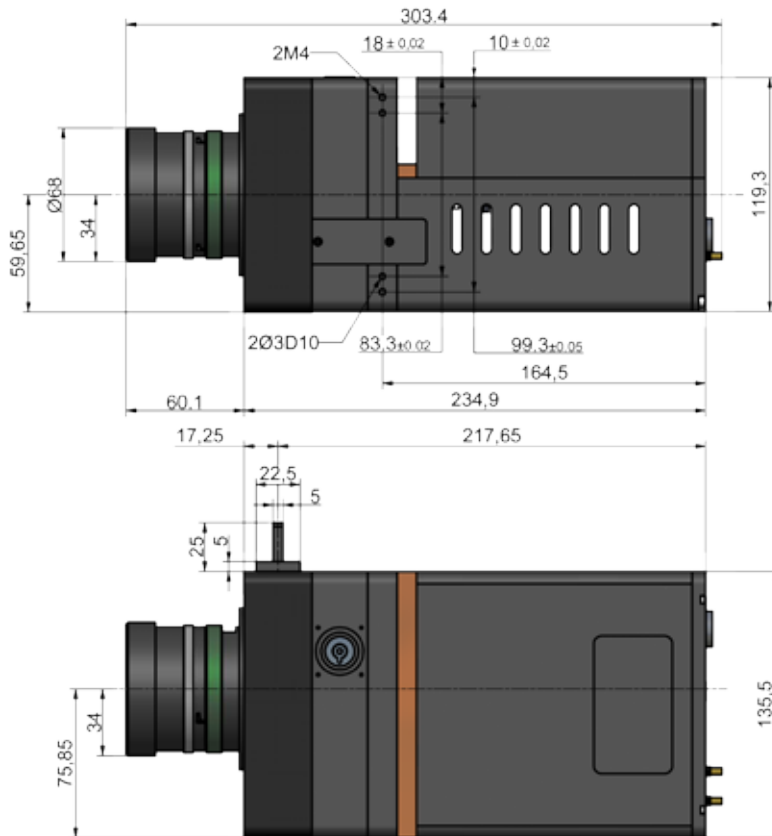

Specifications can be change without notice

RA-03 V2.2 06/2011 ©ELDIM S.A.