

P.5: NEW GENERATION OF VIEWING ANGLE MEASUREMENT SYSTEM AND AUTOMATED CARTOGRAPHY OF LARGE SIZE FLAT PANEL DISPLAYS

Thierry Leroux, Jean Noel Curt and Pierre Boher

ELDIM, 1185 rue d'Epron, 14200 Herouville St Clair, France

Contact author: pboher@eldim.fr

Abstract:

A new generation of optical Fourier Transform viewing angle measurement system is presented. Major improvements have been made on the incidence angle range (up to 88°), sensor sensitivity and resolution (-30°C Peltier cooled CCD and 16 bits resolution), and measurement speed (USB2 bus). This new measurement head can also be included in a fully automated system devoted to the cartography of the emission properties of the flat panel displays. This system based on up to date technology (linear motors, non contact linear encoders), allows movement and adjustment of the new head at any position in front of up to 60 inches screens. Specifications and first results obtained on these new instruments are presented..

Keywords: Viewing angle; luminance; Colorimetry; Cartography.

Introduction

In this paper, we discuss improvement of technologies that are providing useful - fast and accurate - measurements of FPDs characteristics. Optical Fourier Transform (OFT) based equipments are now widely used to measure angle dependant characteristics and view-ability which are from the point of view of the researcher, the manufacturer and even the final user, the most preminent characteristic to qualify [1-3]. The drastic improvement of the LCD characteristics these last few years have made the users of this kind of technologies more demanding in terms of accuracy and viewing angle. ELDIM has long been recognized for the quality of it's OFT heads. Recently a new generation of OFT equipment has been developed. Some details are given here after. Also the development of TV market has introduced new needs in term of homogeneity on all the surface of these large size displays. An automated system dedicated to the cartography is also presented.

New generation of OFT equipment

Description:

Optical Fourier Transform (OFT) instrument offers the opportunity to measure simultaneously the light emitted by a display for a large range of incidence and azimuth angles. This approach has been first proposed in 1987 by Deutsch [4]. It is based on the use of Fourier optics objectives to collect the sample angular distribution of light. A simplified diagram is shown Figure 1. A first objective **3** is used in order to provide an image in the Fourier Plane **2** of the angular emission characteristic of the DUT **1**. A field lens **4** is then used to bend the rays toward a second

objective **6**. An additional role for this lens is to conjugate - together with the objective **3** - the plane of the DUT and the plane of an iris **5**. This iris is used to define the measurement area and to trim its size. The second objective **6** is used to image the Fourier distribution of light on a CCD sensor **7**. This measurement principle enables to carry out luminance or color coordinates measurements rapidly for a large angular aperture and with nearly no limitation in the angle step.

A key part of the instrument is the Fourier objective **3** that can be quite complicated when large angles are to be examined. Further complications also arise in the design due to the minimization of stray light and polarization effect which should be kept to a minimum. One main improvement of the new OFT equipment compared to the old systems is that the angular aperture is extended up to $\pm 88^\circ$ thanks to a new optical design including aspheric lenses. This new capability push the OFT technology to its limits (the best existing instruments were reaching only $\pm 80^\circ$ in a recent past). Main characteristics of the new instrument compared to old one's are reported in Table I. Another main improvement concerns the CCD sensor which is cooled down to -30°C compare to -15°C for the previous generations. Dark current noise is then reduced by a factor of 8 and since the connection to the computer is 10 times more rapid than previously, the measurement time can be reduced substantially (cf. Table I). As show in the photograph of figure 2, the system is modular. The objective, the filter wheel and the CCD head can be dismounted easily for better maintenance. All the measurement conditions (spot size, polarization, filters...) can be selected automatically.

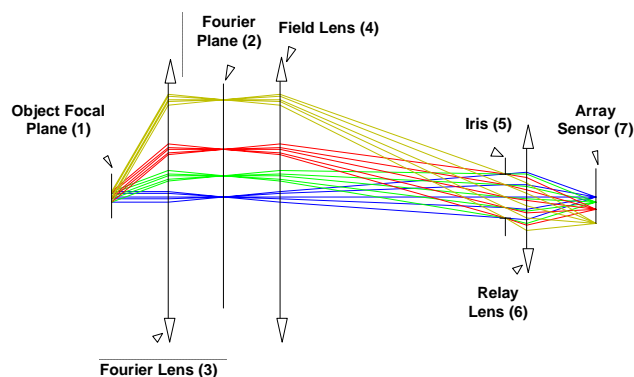

Figure 1. OFT equipment basis principal

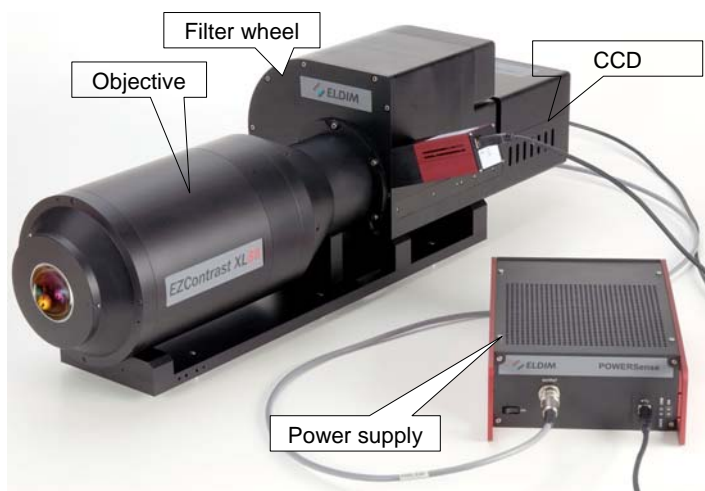

Figure 2. Photograph of the EZContrast XL88

Specifications	EZLite Micro	EZLite	EZContrast 160	EZContrast XL88
Incidence angle	$\pm 30^\circ$	$\pm 60^\circ$	$\pm 80^\circ$	$\pm 88^\circ$
Working distance	50mm	4.5mm	1.5mm	1.0mm
Angular accuracy	$<0.15^\circ$	$<0.15^\circ$	$<0.15^\circ$	$<0.10^\circ$
Luminance accuracy	$<3\%$	$<3\%$	$<3\%$	$<3\%$
Meas. time luminance	$<10s$	$<10s$	$<15s$	$<3s$
Meas. time color	$<30s$	$<30s$	$<90s$	$<10s$

Table 1. Main specifications of the ELDIM OFT instruments

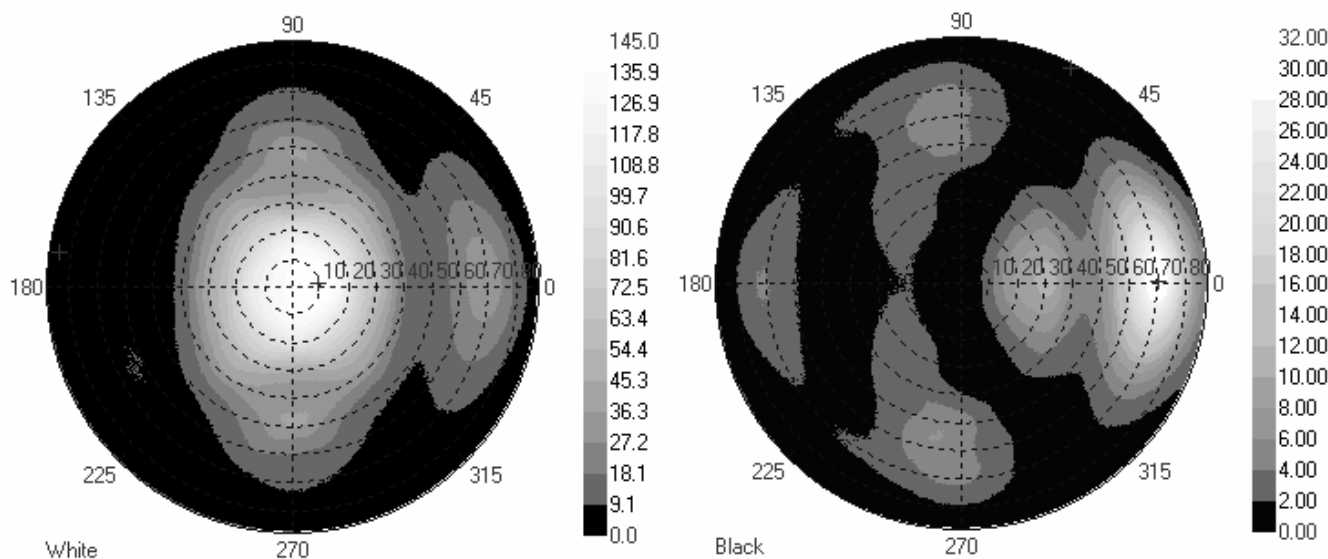

Figure 3. Black and white measurements on a typical notebook LCD display

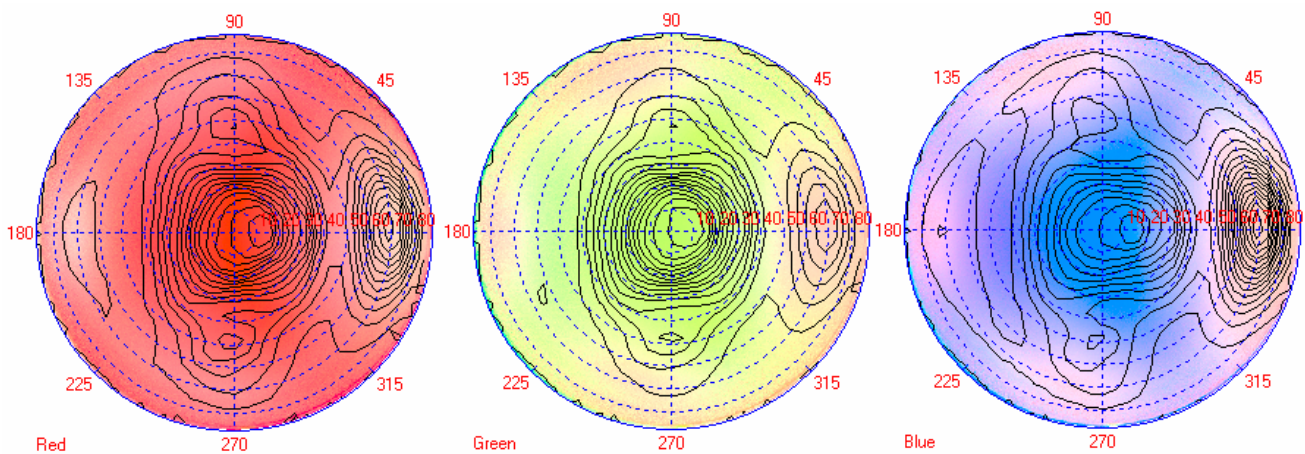

Figure 4. Colorimetric measurement on the same notebook LCD display as figure 3

Experimental results:

Black and white luminance measurements made on the LCD display of a typical notebook are reported in figure 3. One can see all the details of the complex emission diagram of this kind of display. The maximum of luminosity and contrast is obtained near normal incidence (the usual working condition for this type of display), but large variation can be detected outside this situation. In particular a parasitic light leakage can be detected around 70° along one azimuth (due to the tilt angle of the liquid crystal). The large angular aperture of the instrument is useful to get all the details of this complex diagram.

Colorimetric measurements of the same display are also reported in figure 4. The contrast on the figures is only representative of the color variations. One can see that the complexity of the different diagrams is comparable to what we have observed for the luminance diagram. The large angular aperture of the instrument is again useful to get a complete picture of the display color behavior. Sharp colorimetric variations can be detected even near the very grating incidence.

Automated system for large size FPD cartography

With the development of large size display for TV application, the need to check the emission properties on the entire surface of the display becomes mandatory. It is why we have recently developed a dedicated automated system. It is designed to meet demands as required for visual performance evaluation in industry scale in LCD research and development as well as for quality control purposes. The FPD up to 60 inches of diagonal is deposited on a panel holder and does not move during the measurements (cf. figure 5). The EZContrast head is moved rapidly by a 3 axis high resolution positioning stage in front of any point of the display. The two translations X and Y are equipped with linear motors and non contact linear encoders for higher speed and reliability. The system is built on a granite structure to ensure stiffness and stability. Some mechanical characteristics of the system are summarized in Table II. The working distance of the head is automatically adjusted with an optical sensor integrated in the head. The windows based software is operator oriented for easier and efficient quality control of the screens.

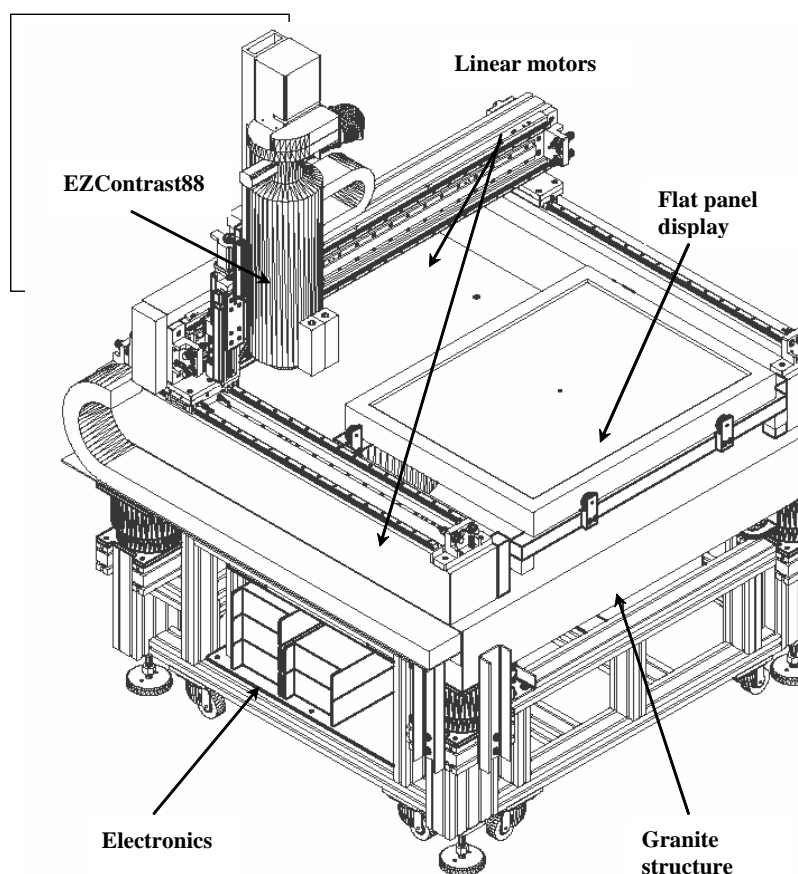

Figure 5. Schematic diagram of the automated angle of view cartography system

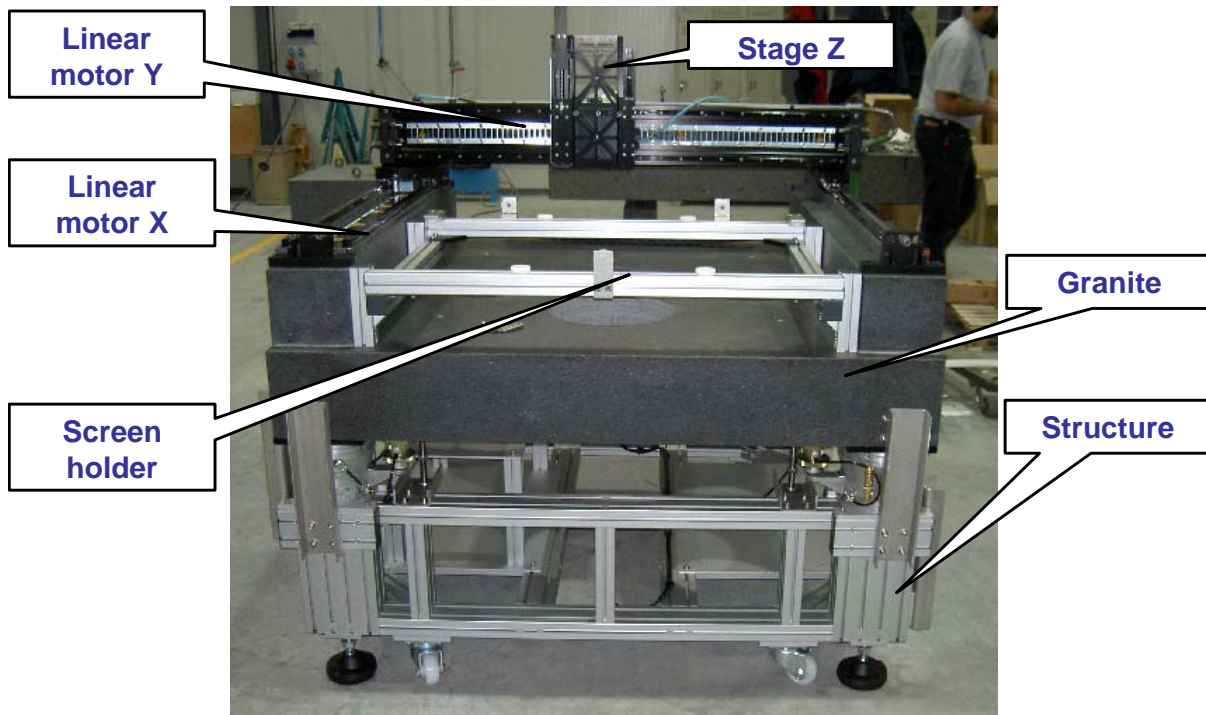

Figure 6. Photograph of the XYZ stage of the automated angle of view cartography system

Specifications	X Stage	Y Stage
Length (mm)	1600	900
Moving mass (Kg)	130	60
Accuracy (μm)	± 50	± 50
Repeatability (μm)	± 25	± 25
Max speed (m/s)	0.8	0.7
Moving time (full range) (s)	3	2

Table II: Main specifications of the XY stage

Conclusion

In the proposed paper, we have presented a new generation of OFT equipment that push to the limits this kind of technology allowing measurement up to $\pm 88^\circ$ for all the azimuth. The sensor head has also been improved in terms of sensitivity and resolution. So, better quality measurement can now be made 5 to 10 times more rapidly than previously.

In order to cover the needs in terms of automated measurement on large size displays, a new automated system has also been design with up to date technology in terms of positioning and speed. It allows rapid and accurate cartography of the entire surface of 60 inches displays using the new generation of OFT equipment.

References

1. "Fast contrast vs. viewing angle measurements for LCDs", T. Leroux, Eurodisplay'93 Proceedings, 447, 1993
2. "Fast analysis of LCD Contrast and color coordinates vs. viewing angle", T. Leroux, SID'1995 digest, 739, 1995
3. "Modern methods for the electro-optical characterization of displays", T. Leroux, DIS'2000 digest, 2000
4. J. C. Deutsch, Patent # FR87-04944, 1987